

# DEADEND LOOP CLAMPS

1-1

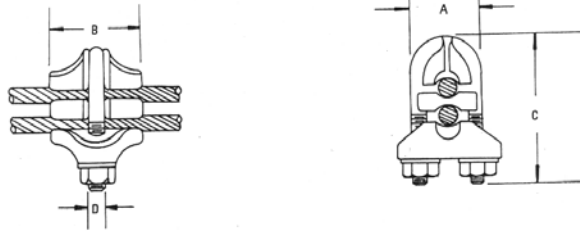

CATALOG NUMBER	CONDUCTOR RANGE MAIN	CONDUCTOR RANGE TAP	DIM. A	DIM. B	DIM. C	DIM. J	APPROX. WEIGHT PER 100
PC - 71B	#6 SOL. - 2/0 STR. AAC #8 - 2/0 ACSR	#6 SOL. - 2/0 STR. AAC #8 - 2/0 ACSR	2"	2"	2 7/8"	3/8"	44 LBS.
PC - 72B	#6 SOL. - 2/0 STR. AAC #8 - 2/0 ACSR	#6 SOL. - 2/0 STR. AAC #8 - 2/0 ACSR	2 1/4"	2 1/4"	3 3/8"	1/2"	75 LBS.
PC - 73B	1/0 SOL. - 400 MCM AAC 1/0 - 336.4 MCM ACSR	#6 SOL. - 1/0 STR. AAC #8 - 1/0 ACSR	2 5/8"	2 3/4"	4"	1/2"	110 LBS.
PC - 74B	1/0 SOL. - 400 MCM AAC 1/0 - 336.4 MCM ACSR	1/0 SOL. - 400 MCM AAC 1/0 - 336.4 MCM ACSR	2 5/8"	2 3/4"	4"	1/2"	120 LBS.
PC - 75B	336.4 - 954 MCM AAC 300 - 795 MCM ACSR	#6 SOL. - 1/0 STR. AAC #8 - 1/0 ACSR	3"	3 1/4"	4 5/8"	1/2"	145 LBS.
PC - 77B	336.4 - 1033.5 MCM AAC 300 - 954 (45/7) ACSR	336.4 - 1033.5 MCM AAC 300 - 954 (45/7) ACSR	3 3/8"	3 1/2"	5 3/8"	5/8"	195 LBS.

THE ABOVE CLAMPS ARE PRIMARILY USED FOR ACSR LOOP DEADENDS. THEY MAY ALSO BE USED FOR SPLICING OR TAP CONNECTIONS. IN SPLICING CONNECTIONS IT IS RECOMMENDED THE INSTALLER USES A SEALANT. PLEASE ADD THE SUFFIX "XB" TO THE CATALOG NUMBER FOR THIS FEATURE.

# SINGLE GROOVE GROUND CLAMPS

1-2

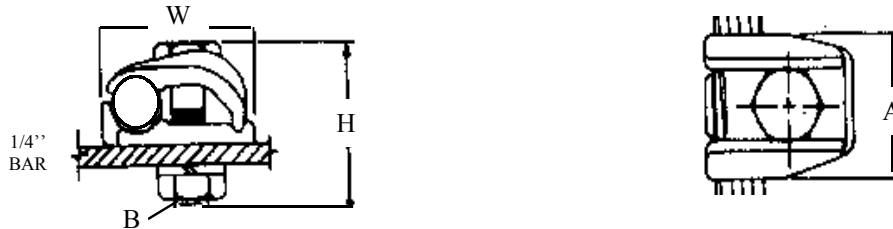

CATALOG NUMBER	COPPER CONDUCTOR RANGE	COPPER CONDUCTOR DIAMETER	DIM. A	DIM. H	DIM. W	DIM. B	APPROX. WEIGHT PER 100
SGGC - 141	6 SOL. - 2/0 STR.	.162" - .419"	1 1/4"	2"	1 5/8"	1/2"	41 LBS.
SGGC - 141A - 02	4 SOL. - 300 MCM	.204" - .630"	1 1/2"	2 1/8"	1 7/8"	1/2"	50 LBS.
SGGC - 141 - 03	300 - 500 MCM	.629" - .813"	2"	2 3/8"	2 1/2"	1/2"	94 LBS.
SGGC - 141 - 07	4 SOL. - 300 MCM	.204" - .630"	1 3/4"	2 1/4"	2 1/8"	5/8"	86 LBS.
SGGC - 141 - 10	750 - 1000 MCM	.998" - 1.152"	2 1/4"	3 3/8"	3"	5/8"	165 LBS.

THE ABOVE SINGLE GROOVE GROUND CLAMPS ARE USED TO CLAMP COPPER CABLE TO A FLAT BAR. IF THE FLAT BAR IS THICKER THAN THE 1/4" SHOWN, THEN ADD THE THICKNESS TO THE PART NUMBER TO OBTAIN LONGER BOLTS. FOR EXAMPLE : #SGGC - 141A - 02 - 1/2 FOR 1/2" BAR.

MATERIAL : BODY - BRONZE ALLOY  
HARDWARE - STAINLESS STEEL, GALVANIZED STEEL, OR SILICON BRONZE

# DOUBLE GROOVE GROUND CLAMPS

1-3

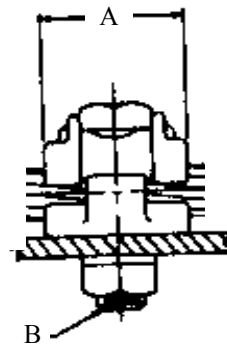
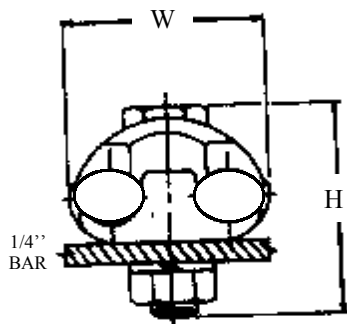

CATALOG NUMBER	COPPER CONDUCTOR RANGE	DIM. A	DIM. H	DIM. W	DIM. B	APPROX. WEIGHT PER 100
DGGC - 143 - 01	4 SOL. - 2/0 STR.	1 1/2"	2 1/4"	2"	3/8"	59 LBS.
DGGC - 143A - 02	4 SOL. - 300 MCM	1 1/2"	2 5/8"	2 1/4"	1/2"	68 LBS.
DGGC - 143B - 02	4 SOL. - 250 MCM	1 3/4"	2 3/4"	2 5/16"	5/8"	90 LBS.
DGGC - 143 - 03	300 - 500 MCM	2"	2 3/4"	2 5/8"	1/2"	83 LBS.

THE ABOVE DOUBLE GROOVE GROUND CLAMPS ARE USED TO CLAMP TWO COPPER CABLES TO FLAT BAR. IF THE FLAT BAR IS THICKER THAN THE 1/4" SHOWN, THEN ADD THE THICKNESS TO THE CATALOG NUMBER TO OBTAIN LONGER BOLTS. FOR EXAMPLE : #DGGC - 143 - 02 - 1/2 FOR 1/2" BAR. FOR GALVANIZED HARDWARE ADD THE SUFFIX "G" TO THE CATALOG NUMBER.

MATERIAL : BODY - BRONZE ALLOY  
HARDWARE - STAINLESS STEEL, GALVANIZED STEEL, OR SILICON BRONZE

# HOT LINE CLAMPS ALUMINUM

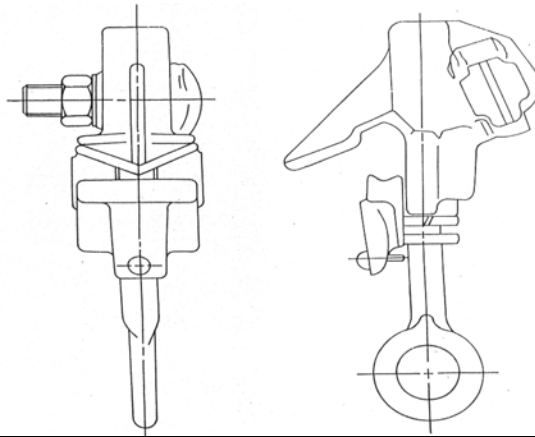

CATALOG NUMBER	TYPE OF CONNECTION MAIN TAP	MAIN LINE RANGE		TAP LINE RANGE		RECOMMENDED TORQUE OF EYE SCREW AND TERMINAL	WEIGHT PER 100 PIECES
		DIA. INCHES	SIZE MCM/AWG	DIA. INCHES	SIZE MCM/AWG		
UHC520AA	ALUM. TO ALUM.	.128" TO .414"	6 ACSR TO 1/0 ACSR	.128" TO .438"	6 ACSR TO 1/0 ACSR	180 INCH - POUND	40 LBS.
UHC520AGP	GENERAL PURPOSE ALUMINUM BODY	.128" TO .414"	6 ACSR TO 1/0 8 SOL. TO 2/0 CU.	.128" TO .414"	6 ACSR TO 1/0 8 SOL. TO 2/0 CU.	180 INCH - POUND	42 LBS.
UHC530AA	ALUM. TO ALUM.	.162" TO .745"	6 ACSR TO 336 ACSR	.162" TO .547"	6 ACSR TO 3/0 ACSR	200 INCH - POUND	68 LBS.
UHC530AC	ALUM. TO COPPER	.162" TO .745"	6 ACSR TO 336 ACSR	.162" TO .547"	6 SOL. CU. TO 4/0 STR.	200 INCH - POUND	72 LBS.
UHC530AGP	GENERAL PURPOSE ALUMINUM BODY	.162" TO .745"	6 ACSR TO 336 ACSR	.162" TO .547"	6 ACSR TO 3/0 6 CU. TO 4/0	200 INCH - POUND	70 LBS.
UHC535AA	ALUM. TO ALUM.	.250" TO .806"	4 ACSR TO 397.5 ACSR	.204" TO .806"	4 STR. AL. TO 397.5	300 INCH - POUND	70 LBS.
UHC535AGP	GENERAL PURPOSE ALUMINUM BODY	.250" TO .806"	4 ACSR TO 397.5 ACSR	.204" TO .806"	4 SOL. CU. TO 397.5	300 INCH - POUND	87 LBS.
UHC540AA	ALUM. TO ALUM.	.502" TO 1.031"	4 ACSR W/Armor TO 266.8 W/Armor	.198" TO .703"	6 ACSR TO 266.8 ACSR	250 INCH - POUND	107.5 LBS.
UHC540AC	ALUM. TO COPPER	.502" TO 1.031"	4 ACSR W/Armor TO 266.8 W/Armor	.198" TO .703"	4 SOL. CU. TO 300 STR.	250 INCH - POUND	109 LBS.
UHC540AGP	GENERAL PURPOSE ALUMINUM BODY	.502" TO 1.031"	4 ACSR W/Armor TO 266.8 W/Armor	.198" TO .703"	6 ACSR TO 266.8 4 SOL. CU. TO 300	250 INCH - POUND	110 LBS.
UHC545AA	ALUM. TO ALUM.	.939" TO 1.490"	4/0 ACSR W/Armor 556.5 ACSR W/Armor	.198" TO .703"	6 ACSR TO 266.8 ACSR	250 INCH - POUND	125 LBS.
UHC545AGP	GENERAL PURPOSE ALUMINUM BODY	.939" TO 1.49"	4/0 ACSR W/Armor 556.5 ACSR W/Armor	.198" TO .703"	6 ACSR TO 266.8 4 SOL. CU. TO 300	250 INCH - POUND	128 LBS.

THE UHC HOT LINE CLAMPS ARE OFFERED IN A VARIETY OF CONDUCTOR COMBINATIONS. EACH EYE SCREW IS FILLED WITH INHIBITOR TO PREVENT CORROSION AND PROMOTE AN EASE OF OPERATION. CLAMPS THAT END WITH THE SUFFIX "GP" HAVE A FORTIFIED PLATING FOR FURTHER PROTECTION. ALSO OFFERED IS THE CHOICE OF A 1/2" TAP BOLT INSTEAD OF THE STANDARD 3/8". ADD THE SUFFIX -1/2" TO THE NUMBER FOR THIS FEATURE. CONTACT UPI FOR SPECIFIC DRAWINGS ON ANY OF THE ABOVE CLAMPS.

# WIDE RANGE HOT LINE CLAMPS ALUMINUM

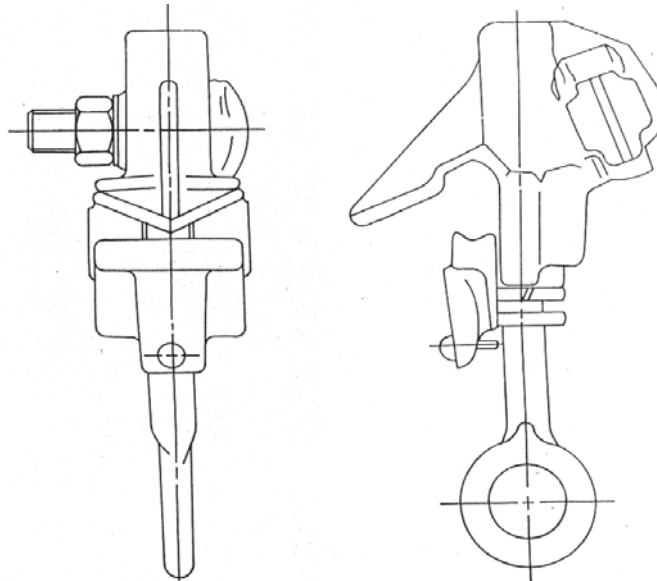

CATALOG NUMBER	TYPE OF CONNECTION MAIN      TAP	MAIN LINE RANGE		TAP LINE RANGE		RECOMMENDED TORQUE OF EYE SCREW AND TERMINAL	WEIGHT PER 100 PIECES
		DIA. INCHES	SIZE MCM/AWG	DIA. INCHES	SIZE MCM/AWG		
UAH - 00	ALUM. TO ALUM.	.128" TO .477"	8 ACSR TO 2/0 ACSR	.128" TO .419"	8 ACSR TO 1/0 ACSR	180 INCH - POUND	48 LBS.
UAH - 00 - GP	GENERAL PURPOSE ALUMINUM BODY	.128" TO .477"	8 ACSR TO 2/0 ACSR	.128" TO .419"	8 ACSR TO 1/0 8 SOL. CU. TO 2/0	180 INCH - POUND	48 LBS.
UAH - 4	ALUM. TO ALUM.	.157" TO .905"	8 ACSR TO 556.5 ACSR	.157" TO .593"	6 ACSR TO 4/0 ACSR	200 INCH - POUND	76 LBS.
UAH - 4 - GP	GENERAL PURPOSE ALUMINUM BODY	.157" TO .905"	8 ACSR TO 556.5 ACSR	.157" TO .593"	6 ACSR TO 4/0 6 SOL. CU. TO 266	200 INCH - POUND	76 LBS.
UAH - 7	ALUM. TO ALUM.	.502" TO 1.031"	3/0 ACSR TO 636 ACSR	.198" TO .703"	6 ACSR TO 266.8 ACSR	250 INCH - POUND	98 LBS.
UAH - 7 - GP	GENERAL PURPOSE ALUMINUM BODY	.502" TO 1.031"	3/0 ACSR TO 636 ACSR	.198" TO .703"	6 ACSR TO 266.8 4 CU. TO 350	250 INCH - POUND	98 LBS.

*THE UAH HOT LINE CLAMPS OFFER THE CUSTOMER A WIDER RANGE OF CONDUCTOR COMBINATIONS. EACH EYE SCREW IS FILLED WITH INHIBITOR TO PREVENT CORROSION AND PROMOTE AN EASE OF OPERATION. CLAMPS THAT END WITH THE SUFFIX "GP" HAVE A FORTIFIED PLATING FOR FURTHER PROTECTION. ALSO OFFERED IS THE CHOICE OF A 1/2" TAP BOLT INSTEAD OF THE STANDARD 3/8". ADD THE SUFFIX -1/2" TO THE NUMBER FOR THIS FEATURE. FOR CLAMPS INJECTED WITH SEALANT IN MAIN JAW AND INDIVIDUALLY BAGGED, ADD -XB. CONTACT UPI FOR SPECIFIC DRAWINGS ON ANY OF THE ABOVE CLAMPS.*

# HOT LINE CLAMPS BRONZE

1-6

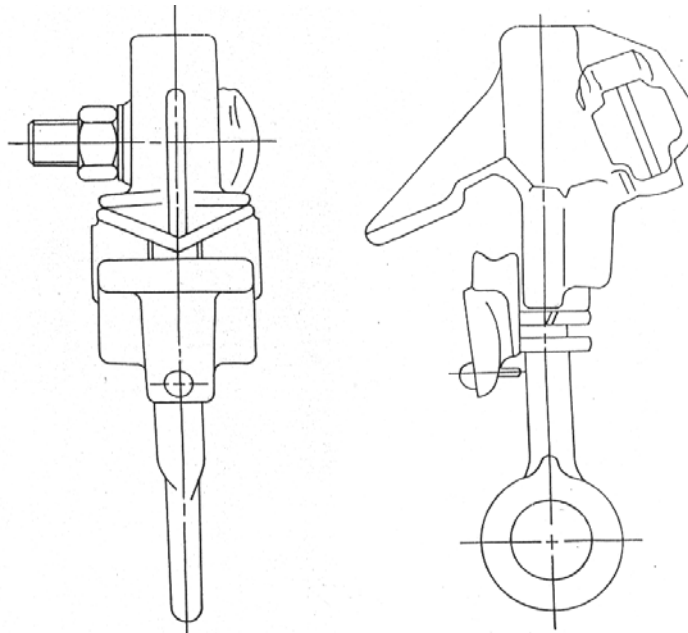

CATALOG NUMBER	TYPE OF CONNECTION MAIN TAP	MAIN LINE RANGE		TAP LINE RANGE		RECOMMENDED TORQUE OF EYE SCREW AND TERMINAL	WEIGHT PER 100 PIECES
		DIA. INCHES	SIZE MCM/AWG	DIA. INCHES	SIZE MCM/AWG		
UHC520CC	COPPER TO COPPER	.128" TO .414"	8 SOL. CU. TO 2/0 STR.	.128" TO .438"	8 SOL. CU. TO 2/0 STR.	180 INCH - POUND	69 LBS.
UHC520GP	GENERAL PURPOSE BRONZE BODY	.128" TO .414"	6 ACSR TO 1/0 8 SOL. CU. TO 2/0	.128" TO .438"	6 ACSR TO 1/0 8 SOL. CU. TO 2/0	180 INCH - POUND	71 LBS.
UHC530CC	COPPER TO COPPER	.162" TO .745"	6 SOL. CU. TO 400 STR.	.162" TO .547"	6 SOL. CU. TO 4/0 STR.	200 INCH - POUND	132 LBS.
UHC530GP	GENERAL PURPOSE BRONZE BODY	.162" TO .745"	6 SOL. CU. TO 400 STR.	.162" TO .547"	6 ACSR TO 3/0 6 SOL. CU. TO 4/0	200 INCH - POUND	136 LBS.
UHC540CC	COPPER TO COPPER	.502" TO 1.031"	2 CU. W/ Armor 300 CU. W/ Armor	.198" TO .703"	4 SOL. CU. TO 300 CU.	250 INCH - POUND	96 LBS.
UHC540GP	GENERAL PURPOSE BRONZE BODY	.502" TO 1.031"	2 CU. W/ Armor 300 CU. W/ Armor	.198" TO .703"	6 ACSR TO 266.8 4 SOL. CU. TO 300	250 INCH - POUND	98 LBS.

THE UHC SERIES OF BRONZE HOT LINE CLAMPS ARE PRIMARILY MADE FOR USE ON COPPER CONDUCTOR. EACH EYE SCREW IS FILLED WITH INHIBITOR TO PREVENT CORROSION AND PROMOTE AN EASE OF OPERATION. CLAMPS THAT END WITH THE SUFFIX "GP" HAVE A TIN PLATING FOR FURTHER PROTECTION. ALSO OFFERED IS THE CHOICE OF A 1/2" TAP BOLT INSTEAD OF THE STANDARD 3/8". ADD THE SUFFIX -1/2" TO THE NUMBER FOR THIS FEATURE. FOR CLAMPS INJECTED WITH SEALANT IN MAIN JAW AND INDIVIDUALLY BAGGED, ADD -XB. CONTACT UPI FOR SPECIFIC DRAWINGS ON ANY OF THE ABOVE CLAMPS.

# ALUMINUM PARALLEL CONNECTOR

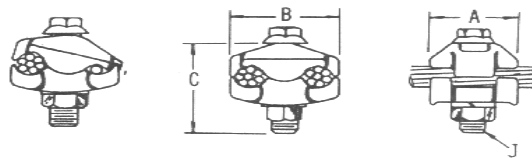
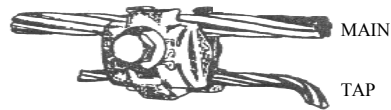

CATALOG NUMBER	MAIN LINE RANGE	TAP LINE RANGE	LENGTH DIA. INCHES A	WIDTH DIA. INCHES B	HEIGHT DIA. INCHES C	BOLT J DIA. INCHES	WEIGHT PER 100 PIECES
PC - 51 - A	8 SOL. - 1/0 STR. AAC 8 ACSR - 1/0 ACSR	8 SOL. - 2 STR. AAC 8 ACSR - 2 ACSR 8 SOL. - 2 STR. CU.	1-1/8"	1-13/32"	1-1/2"	5/16"	14 LBS.
PC - 51 - C	8 SOL. - 1/0 STR. AAC 8 ACSR - 1/0 ACSR	8 SOL. - 1/0 STR. AAC 8 ACSR - 1/0 ACSR 8 SOL. - 1/0 STR. CU.	1-1/4"	1-17/32"	2"	3/8"	19 LBS.
PC - 52 - A	8 SOL. - 2/0 STR. AAC 8 ACSR - 2/0 ACSR	8 SOL. - 2/0 STR. AAC 8 ACSR - 2/0 ACSR 8 SOL. - 2/0 STR. CU.	1-3/8"	1-21/32"	2"	3/8"	22 LBS.
PC - 52 - C	1 SOL. - 400 MCM AAC 1 ACSR - 336.4 ACSR.	8 SOL. - 2/0 STR. AAC 8 ACSR - 2/0 ACSR 8 SOL. - 2/0 STR. CU.	2"	2-11/32"	2-1/4"	3/8"	28 LBS.

THE ABOVE PC SERIES OF ALUMINUM PARALLEL CONNECTORS ARE FURNISHED WITH A COPPER TAP LINER AND ARE TO BE USED FOR ALUMINUM TO COPPER CONNECTIONS ONLY. IT IS RECOMMENDED THAT THE CONNECTORS BE PREFILLED WITH SEALANT. THIS CAN BE DONE AT THE FACTORY BY ADDING THE SUFFIX "XB" TO THE PART NUMBER. WITH THE USE OF THIS CLAMPS INTERLOCKING FEATURES, THE TOP AND BOTTOM PART OF THE CLAMP ARE ABLE TO FULLY EMBRACE ANY CONDUCTOR COMBINATIONS. OTHER SIZES ARE AVAILABLE UPON REQUEST. CONTACT UPI FOR SPECIFIC DRAWINGS ON ANY OF THE ABOVE CONNECTORS.

# BRONZE PARALLEL CONNECTOR

1-8

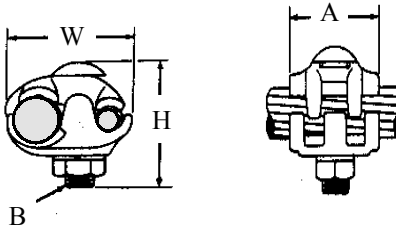

CATALOG NUMBER	CONDUCTOR MAIN RANGE	CONDUCTOR TAP RANGE	DIM. A	DIM. W	DIM. H	DIM. B	WT. EACH
BPC - 1601	1/0 SOL. - 4/0 STR. CU.	8 SOL. - 1 STR. CU.	2"	1 3/4"	2"	3/8"	.56 LBS.
BPC - 1602	1/0 SOL. - 400 MCM CU.	8 SOL. - 3/0 STR. CU.	2 3/8"	2 1/4"	2 3/4"	1/2"	1.04 LBS.

THE ABOVE BRONZE PARALLEL CONNECTORS ARE USED PRIMARILY FOR COPPER TO COPPER CONNECTIONS. THIS SERIES IS FURNISHED WITH A SINGLE CENTER BOLT.

MATERIAL : BODY - HIGH STRENGTH BRONZE ALLOY  
HARDWARE - SILICON BRONZE

# BRONZE STRAIGHT TERMINAL CONNECTOR

1-9

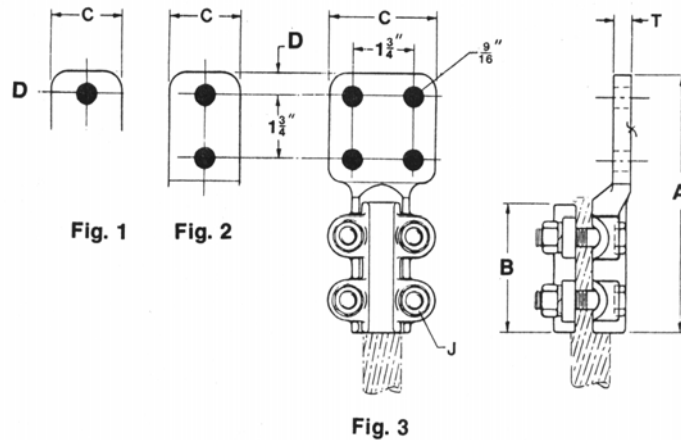

CATALOG NUMBER	FIG. NO.	COPPER RANGE SMALL GROOVE	COPPER RANGE LARGE GROOVE	COPPER DIA. INCHES	DIM. A	DIM. B	DIM. D	DIM. T	DIM. C	WT. EA. LBS.
BSL - 020 - A	1	6 SOL. - 2STR.	2 SOL. - 2/0 STR.	.162 - .149	4 1/2"	2 1/2"	3/4"	1/4"	1 1/2"	1.2
BSL - 022 - B	2	6 SOL - 2 STR.	2 SOL. - 2/0 STR	.162 - .149	5 3/4"	2 1/2"	5/8"	1/4"	1 1/2"	1.5
BSL - 022 - C	3	6 SOL - 2 STR.	2 SOL. - 2/0 STR	.162 - .149	5 7/8"	2 1/2"	5/8"	1/4"	3"	1.8
BSL - 025 - B	2	6 SOL - 1/0 STR	2/0 SOL - 250	.204 - .575	6 1/8"	2 3/4"	5/8"	1/4"	3"	1.4
BSL - 025 - C	3	6 SOL - 1/0 STR	2/0 SOL - 250	.204 - .575	6 1/8"	2 3/4"	5/8"	1/4"	3"	2.0
BSL - 050 - B	2	1/0 SOL - 4/0	250 - 500 MCM	.325 - .813	6 1/4"	2 3/4"	5/8"	3/8"	2"	2.1
BSL - 050 - C	3	1/0 SOL - 4/0	250 - 500 MCM	.325 - .813	6 1/4"	2 3/4"	5/8"	5/16"	3"	2.4

THE ABOVE BSL SERIES OF BRONZE ALLOY TERMINALS ARE FURNISHED WITH 3/8" DIAMETER HEX HEAD BOLTS. THESE CONNECTORS ARE USED FOR CONNECTING COPPER CONDUCTOR TO COPPER FLAT. THE REVERSIBLE FEATURE OF THIS CLAMP OFFERS THE CUSTOMER A WIDE RANGE OF CONDUCTOR COMBINATIONS. HARDWARE FURNISHED IS SILICON BRONZE OR STAINLESS STEEL. ANGLE CONNECTORS ARE AVAILABLE AND MAY BE REQUESTED BY ADDING THE SUFFIX "Y45" OR "Y90". (MINIMUM PRODUCTION RUN FOR THESE IS REQUIRED)

FOR TIN PLATING ADD "TP" TO THE CATALOG NUMBER

# TANK GROUND CONNECTORS

1-10

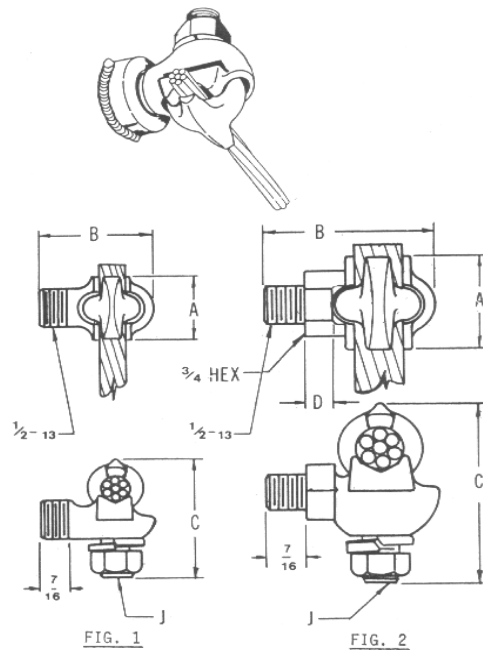

CATALOG NUMBER	COPPER CABLE RANGE	WIRE RANGE DIAMETER INCHES	FIG. NO.	LENGTH DIA. INCHES A	WIDTH DIA. INCHES B	HEIGHT DIA. INCHES C	BOLT J DIA.	WEIGHT PER 100 PIECES
UTGC - 1	10 SOL. - 1 STR.	.102" - .332"	1	7/8"	1-3/8"	1-1/2"	3/8"	20 LBS.
UTGC - 2/0	8 SOL. - 2/0 STR.	.128" - .419"	1	1"	1-17/32"	1-7/8"	3/8"	25 LBS.
UTGC - 250	6 SOL. - 250 STR.	.162" - .575"	2	1-1/4"	2"	2-3/8"	3/8"	34 LBS.

THE ABOVE UTGC SERIES OF TRANSFORMER GROUND CONNECTORS ARE CAST OF HIGH CONDUCTIVITY BRONZE. THESE CONNECTORS ARE FURNISHED WITH A 1/2 INCH 13 THREAD STUD WHICH WILL FIT ALL STANDARD EEI NEMA TRANSFORMERS. FIGURE 1 IN THIS SERIES HAS FLAT SIDES ON THE BODY ALLOWING THE USE OF AN OPEN END WRENCH FOR TIGHTENING. FIGURE "2" IS FURNISHED WITH A HEX HEAD SURFACE. TO OBTAIN ABOVE CONNECTORS WITH AN ALUMINUM BODY, ADD THE PREFIX "A" TO THE CATALOG NUMBER. TIN PLATING IS ALSO AVAILABLE BY ADDING THE SUFFIX "TP" TO THE CATALOG NUMBER.

# LARGE BODY TANK GROUND CONNECTORS

1-11

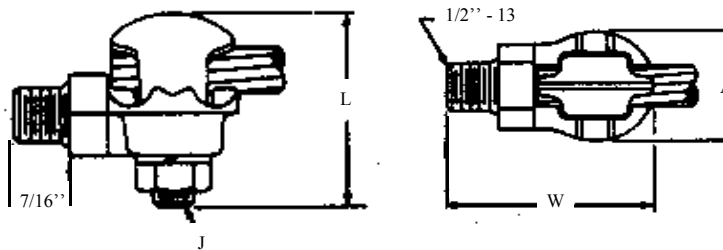

CATALOG NUMBER	COPPER CABLE RANGE	WIRE RANGE DIAMETER INCHES	DIA. INCHES A	DIA. INCHES L	DIA. INCHES W	BOLT J DIA. INCHES	WEIGHT PER 100 PIECES
UTGC - 1L	10 SOL. - 1 STR.	.102" - .332"	1-1/8"	1-5/8"	1-1/2"	3/8"	29 LBS.
UTGC - 2/0L	8 SOL. - 2/0 STR.	.128" - .419"	1-1/4"	1-7/8"	1-7/8"	3/8"	34 LBS.
UTGC - 250L	6 SOL. - 250 STR.	.162" - .575"	1-5/8"	2-3/8"	2-3/8"	1/2"	45 LBS.

THE ABOVE UTGC - L SERIES OF TRANSFORMER GROUND CONNECTORS ARE CAST OF HIGH CONDUCTIVITY BRONZE. THIS STYLE OFFERS A LARGER BODY FOR MORE HEAVY DUTY APPLICATIONS. THESE CONNECTORS ARE FURNISHED WITH A 1/2 INCH 13 THREAD STUD WHICH WILL FIT ALL STANDARD EEI - NEMA TRANSFORMERS. HARDWARE USED IS EITHER A SILICON BRONZE OR A STAINLESS STEEL MATERIAL.