

ANCHOR SHACKLES

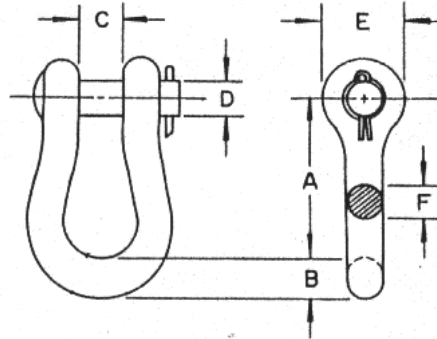

CATALOG NUMBER	DIM. "A"	DIM. "B"	DIM. "C"	DIM. "D"	DIM. "E"	DIM. "F"	ULTIMATE STRENGTH	WEIGHT PER 100
UAS25	2 3/16"	5/8"	7/8"	5/8"	1 3/8"	11/16"	30000 LBS.	75 LBS.
UAS25 – BNC	2 3/16"	5/8"	7/8"	5/8"	1 3/8"	11/16"	30000 LBS.	85 LBS.
UAS25 – L	2 25/32"	5/8"	7/8"	5/8"	1 3/8"	21/32"	30000 LBS.	98 LBS.
UAS25 – L – BNC	2 25/32"	5/8"	7/8"	5/8"	1 3/8"	21/32"	30000 LBS.	110 LBS.
UAS25 – W	3"	5/8"	1 3/4"	5/8"	1 11/16"	1"	25000 LBS.	148 LBS.
UAS – 25 – W – BNC	3"	5/8"	1 3/4"	5/8"	1 11/16"	1"	30000 LBS.	163 LBS.
UAS35	2 25/32"	11/16"	1 1/16"	3/4"	1 11/16"	3/4"	35000 LBS.	145 LBS.
UAS35 – BNC	2 25/32"	11/16"	1 1/16"	3/4"	1 11/16"	3/4"	40000 LBS.	165 LBS.
UAS50	3 1/2"	7/8"	7/8"	3/4"	1 7/8"	3/4"	50000 LBS.	223 LBS.
UAS50 – BNC	3 1/2"	7/8"	7/8"	3/4"	1 7/8"	3/4"	60000 LBS.	242 LBS.
UAS50 – W	3 1/2"	7/8"	1 1/4"	7/8"	1 15/16"	1"	50000 LBS.	222 LBS.
UAS50 – W – BNC	3 1/2"	7/8"	1 1/4"	7/8"	1 15/16"	1"	60000 LBS.	272 LBS.
UAS60 – BNC	3 3/4"	7/8"	1 7/16"	1"	2 1/8"	1 1/8"	80000 LBS.	430 LBS.

THE ABOVE SHACKLES CAN BE FURNISHED WITH A PIN AND COTTER KEY OR SUPPLIED WITH A BOLT, NUT, AND COTTER KEY (BNC) . OTHER SIZES ARE AVAILABLE UPON REQUEST.

THE MATERIAL IS AS FOLLOWS :
 BODY : FORGED STEEL
 CLEVIS PIN OR BOLT : HIGH GRADE STEEL
 COTTER KEY : STAINLESS STEEL
 FERROUS PARTS ARE HOT DIPPED GALVANIZED TO ASTM A153

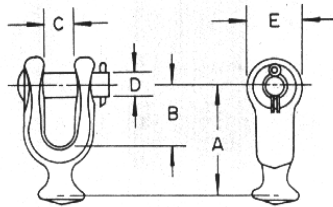

FIG. 1

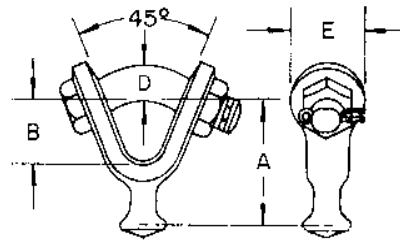
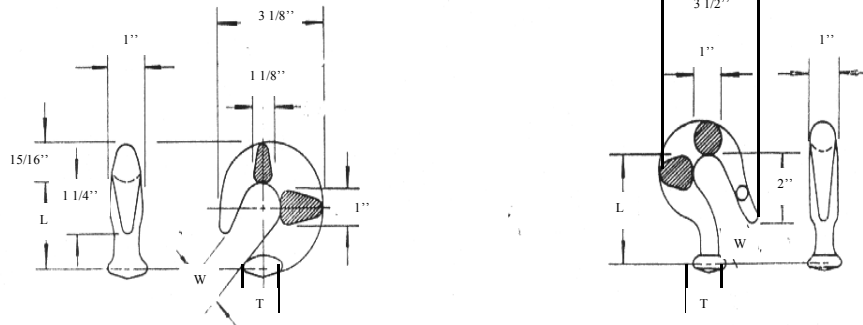

FIG. 2

CATALOG NUMBER	FIG. NO.	BALL ANSI CLASS	DIM. "A"	DIM. "B"	DIM. "C"	DIM. "D"	DIM. "E"	ULTIMATE STRENGTH	WEIGHT PER 100
UBC - 30	1	52 - 3 52 - 5	2 7/8"	1 1/2"	13/16"	5/8"	1 1/2"	30000 LBS.	92 LBS.
UBC - 30 - L	1	52 - 3 52 - 5	3 15/16"	2 1/2"	13/16"	5/8"	1 1/2"	30000 LBS.	120 LBS.
UBC - 50	1	52 - 8 52 - 11	4 3/16"	1 15/16"	15/16"	7/8"	2 3/16"	50000 LBS.	226 LBS.
UBYC - 30	2	52 - 3 52 - 5	3 3/32"	1 1/2"	—	3/4"	1 3/4"	30000 LBS.	188 LBS.
UBYC - 50	2	52 - 8 52 - 11	3 13/16"	1 9/16"	—	7/8"	2 3/16"	50000 LBS.	270 LBS.
UBYC - 50 - L	2	52 - 8 52 - 11	4 1/4"	2"	—	7/8"	2 3/16"	50000 LBS.	282 LBS.

THE ABOVE BALL CLEVISES AND BALL - "Y" CLEVISES ARE USED TO CONNECT BALL AND SOCKET INSULATORS.

THE MATERIAL IS AS FOLLOWS :
 BODY : FORGED STEEL
 CLEVIS PIN OR BOLT : HIGH GRADE STEEL
 COTTER KEY : STAINLESS STEEL
 FERROUS PARTS ARE HOT DIPPED GALVANIZED TO ASTM A153



CATALOG NUMBER	ULTIMATE STRENGTH	DIM. L	DIM. W	DIM. T	APPROX. WEIGHT PER 100
UBH – 30	30000 LBS.	2''	13/16''	23/32''	105 LBS.
UBH – 30L	30000 LBS.	3 1/8''	7/8''	23/32''	132 LBS.

THE ABOVE BALL HOOKS ARE PRIMARILY USED ON ASNI #53 – 2 AND ANSI #53 – 5 SUSPENSION INSULATORS. THE MATERIAL IS STEEL HOT DIPPED GALVANIZED TO ASTM A 153.

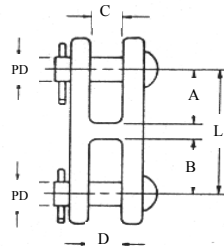

FIGURE 1

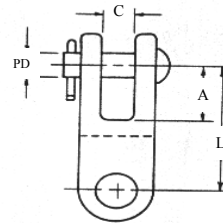
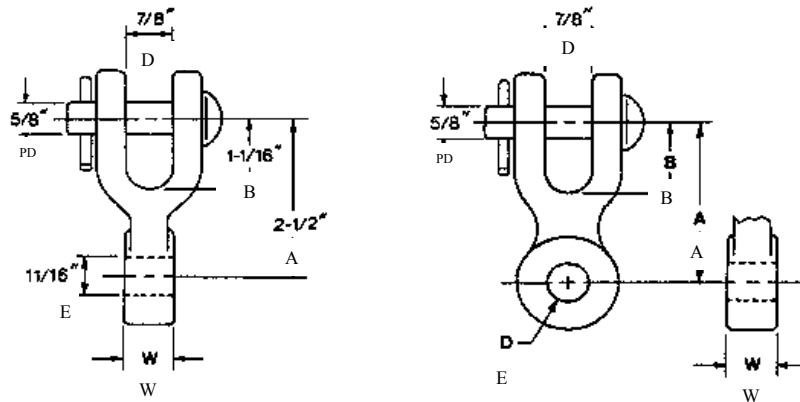

FIGURE 2

CATALOG NUMBER	FIG. NO.	ULTIMATE STRENGTH	DIM. L	DIM. A	DIM. B	DIM. C	DIM. D	DIM. PD	APPROXIMATE WT. PER 100
CC - 1	1	18000 LBS.	2 3/4"	1 1/2"	1 1/4"	3/4"	7/8"	5/8"	225 LBS.
CC - 2	1	25000 LBS.	3 1/8"	1 3/8"	1 7/16"	7/8"	7/8"	3/4"	255 LBS.
CC - 3	1	35000 LBS.	3 9/16"	1 5/8"	1 3/8"	1"	1"	7/8"	280 LBS.
CC - 4	1	30000 LBS.	4"	1 3/4"	1 3/4"	13/16"	13/16"	5/8"	298 LBS.
CC - 5	1	50000 LBS.	4 1/2"	2"	2"	1"	1"	3/4"	395 LBS.
CC - 6 - BNC	1	80000 LBS.	5 1/8"	2 1/4"	2 1/4"	1 1/4"	1 5/8"	1" 1 1/8"	600 LBS.
CC - 1 - 90	2	18000 LBS.	2 3/4"	1 1/16"	1 3/8"	3/4"	7/8"	5/8"	225 LBS.
CC - 2 - 90	2	25000 LBS.	3 1/16"	1 3/8"	1 3/8"	3/4"	7/8"	3/4"	245 LBS.
CC - 3 - 90	2	35000 LBS.	3 3/4"	1 11/16"	1 7/16"	3/4"	1"	7/8"	300 LBS.
CC - 4 - 90	2	30000 LBS.	3"	1 3/8"	1 3/8"	7/8"	1 3/8"	5/8"	255 LBS.
CC - 5 - 90	2	50000 LBS.	4 1/2"	2"	2"	1"	1"	3/4"	395 LBS.

THE ABOVE CLEVIS CLEVIS TYPE FITTINGS ARE PRIMARILY USED TO CONNECT CLEVIS TONGUE INSULATORS TO VARIOUS OTHER HARDWARE WITHIN THE INSULATOR STRING.
TO OBTAIN A BOLT, NUT, AND COTTER KEY, ADD THE SUFFIX - BNC TO THE CATALOG NUMBER.

MATERIAL IS : BODY - DUCTILE IRON
CLEVIS PIN - GALVANIZED STEEL
COTTER KEY - STAINLESS STEEL
BODY AND PIN ARE HOT DIPPED GALVANIZED TO ASTM A 153



CATALOG NUMBER	FIG. NO.	ULTIMATE STRENGTH	DIM. A	DIM. B	DIM. C	DIM. D	DIM. E	DIM. W	DIM. PD	APPROX. WT. PER 100
CE - 1	1	16000 LBS.	2 1/2"	1 1/8"	1/2"	13/16"	5/8"	1/2"	5/8"	155 LBS.
CE - 2	1	20000 LBS.	2 1/2"	1 1/8"	5/8"	13/16"	5/8"	5/8"	5/8"	160 LBS.
CE - 3	1	30000 LBS.	3 1/8"	1 1/2"	5/8"	13/16"	5/8"	5/8"	5/8"	220 LBS.
CE - 4	1	25000 LBS.	2 5/8"	1 1/16"	3/4"	13/16"	5/8"	7/8"	5/8"	175 LBS.
CE - 5	1	25000 LBS.	2 1/2"	1 5/16"	3/4"	13/16"	5/8"	1"	5/8"	170 LBS.
CE - 6	1	25000 LBS.	2 1/2"	1 5/16"	3/4"	13/16"	5/8"	1 3/16"	5/8"	170 LBS.
CE - 7	1	25000 LBS.	2 1/2"	1 1/4"	3/4"	13/16"	5/8"	1 1/4"	5/8"	170 LBS.
CE - 8	1	30000 LBS.	2 1/2"	1 1/4"	3/4"	13/16"	5/8"	1 3/8"	5/8"	175 LBS.
CE - 9	1	30000 LBS.	2 1/2"	1 1/4"	3/4"	13/16"	5/8"	1 7/16"	5/8"	175 LBS.
CE - 14	1	27000 LBS.	3 1/2"	1 1/4"	1"	13/16"	1 1/16"	1 1/4"	5/8"	230 LBS.
CER - 1	2	20000 LBS.	2 5/8"	1 1/4"	11/16"	7/8"	11/16"	1/2"	5/8"	168 LBS.
CER - 2	2	25000 LBS.	2 5/8"	1 1/4"	11/16"	7/8"	11/16"	3/4"	5/8"	168 LBS.
CER - 3	2	18000 LBS.	2 11/16"	1 1/16"	7/8"	13/16"	11/16"	1/2"	5/8"	170 LBS.
CER - 4	2	30000 LBS.	3 3/8"	1 9/16"	7/8"	7/8"	11/16"	5/8"	5/8"	182 LBS.
CER - 5	2	36000 LBS.	3 1/2"	1 1/2"	1"	1"	11/16"	3/4"	3/4"	218 LBS.
CER - 6	2	36000 LBS.	3 1/2"	1 1/2"	1"	1"	15/16"	3/4"	3/4"	208 LBS.
CER - 7	2	36000 LBS.	5 1/2"	2 1/8"	1 1/4"	7/8"	13/16"	3/4"	3/4"	385 LBS.
CER - 8	2	50000 LBS.	5 1/2"	2 1/8"	1"	7/8"	13/16"	1 1/16"	3/4"	295 LBS.
CER - 9	2	60000 LBS.	5 1/2"	2 1/8"	1"	7/8"	13/16"	1 3/4"	7/8"	365 LBS.

THE ABOVE CLEVIS EYES ARE PRIMARILY USED TO CONNECT STRAIN CLAMPS TO CLEVIS TONGUE INSULATORS OR TO YOKE PLATES. THE "CER" TYPE FITTING OFFERS A 90 DEGREE EYE ROTATION FROM THE "CE" SERIES. OTHER SIZES ARE AVAILABLE UPON REQUEST. MINIMUM QUANTITIES MAY APPLY.

MATERIAL : BODY - DUCTILE IRON, CLEVIS PIN - GALVANIZED STEEL, COTTER KEY - STAINLESS STEEL
BODY AND PIN ARE GALVANIZED TO ASTM A 153

Y - CLEVIS CLEVIS & SOCKET Y - CLEVIS

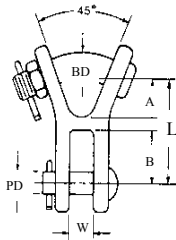

FIGURE 1

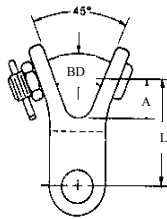

FIGURE 2

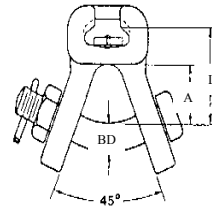

FIGURE 3

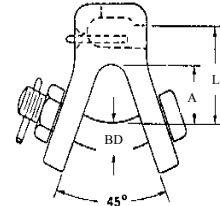

FIGURE 4

CATALOG NUMBER	FIG. NO.	ULTIMATE STRENGTH	DIM. L	DIM. A	DIM. B	DIM. W	DIM. BD	DIM. PD	APPROX. WEIGHT PER 100
UYCC - 30	1	30,000 LBS.	3 1/4"	1 3/8"	1 3/8"	7/8"	3/4"	5/8"	248 LBS.
UYCC - 30 - 90	2	30,000 LBS.	3 1/4"	1 1/2"	1 3/8"	7/8"	3/4"	5/8"	248 LBS.
UYCC - 80	1	80,000 LBS.	7 5/16"	2 1/16"	2 1/4"	1 13/16"	1 1/8"	1 1/8"	497 LBS.
USYC - 30	3	30,000 LBS.	2 3/4"	1 9/16"	—	—	3/4"	—	298 LBS.
USYC - 50	3	50,000 LBS.	2 3/4"	1 9/16"	—	—	7/8"	—	595 LBS.
USYC - 30 - 90	4	30,000 LBS.	2 9/32"	1 3/16"	—	—	3/4"	—	250 LBS.

THE ABOVE Y CLEVIS TO CLEVIS ARE PRIMARILY USED TO ATTACH ASSOCIATED HARDWARE TO CLEVIS TONGUE INSULATORS. THE Y CLEVIS TO SOCKET FITTINGS ARE PRIMARILY USED TO ATTACH ASSOCIATED HARDWARE OR YOKE PLATES TO BALL AND SOCKET INSULATORS.

MATERIAL : BODY - DUCTILE IRON

HARDWARE - STEEL

COTTER PIN - STAINLESS STEEL

BOTH BODY AND HARDWARE ARE HOT DIPPED GALVANIZED TO ASTM A153.

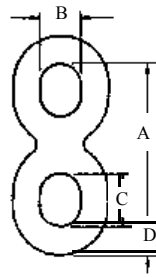

FIG. 1

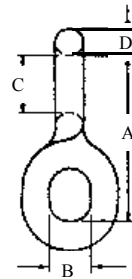

FIG. 2

CATALOG NUMBER	FIG. NO.	DIM. "A"	DIM. "B"	DIM. "C"	DIM. "D"	ULTIMATE STRENGTH	WT. PER 100
F8LK30	1	3 3/8"	7/8"	1 1/8"	9/16"	30000 LBS.	75 LBS.
FL8K30 - 90	2	3 3/8"	7/8"	1 1/8"	9/16"	30000 LBS.	75 LBS.

THE ABOVE CHAIN LINKS ARE PRIMARILY USED TO ALLOW PROPER CLEARANCE WHEN CONNECTING ASSOCIATED HARDWARE TO THE TOWER PAD. THEY CAN ALSO BE USED AMONG A STRING OF INSULATORS.

MATERIAL : HOT DIPPED GALVANIZED STEEL TO ASTM A153

FIG. 1

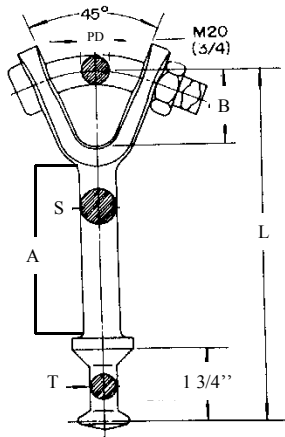

FIG. 2

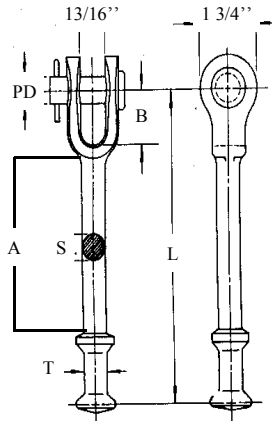
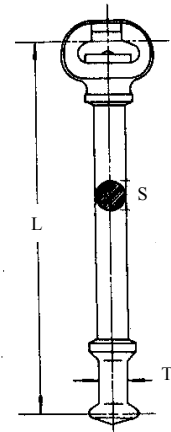

FIG. 3



CATALOG NUMBER	FIG. NO.	ULTIMATE STRENGTH	DIM. L	DIM. A	DIM. B	DIA. S	DIA. T	PD	WT. PER 100
HLBC - 30 PICTURED	1	30000 LBS.	9 3/4"	5 9/16"	1 1/2"	7/8"	23/32"	3/4"	278 LBS.
HLBC - 50	1	50000 LBS.	10 3/16"	6 9/16"	1 1/2"	7/8"	57/64"	7/8"	368 LBS.
HLBC - 30 PICTURED	2	30000 LBS.	9 9/16"	5 7/8"	1 3/4"	7/8"	23/32"	5/8"	243 LBS.
HLBC - 50	2	50000 LBS.	10 1/16"	5 3/8"	1 7/8"	7/8"	57/64"	7/8"	348 LBS.
HLSC - 30	3	30000 LBS.	9 3/4"	—	—	7/8"	23/32"	7/8"	305 LBS.

THE ABOVE HOT LINE LINKS ARE PRIMARILY USED TO CONNECT BALL AND SOCKET INSULATORS TO OTHER HARDWARE IN AN INSULATOR STRING. THE SHOULDERS SHOWN WILL ALLOW THE USE OF HOT LINE TOOLS. THE 30000# LINKS ARE FOR USE WITH CLASS 52 - 3 AND 52 - 5 INSULATORS. THE 50000# LINKS ARE FOR USE WITH CLASS 52 - 8 AND 52 - 11 INSULATORS.

MATERIAL : BODY IS HOT DIPPED GALVANIZED STEEL TO ASTM A153
CLEVIS PIN IS STEEL GALVANIZED TO ASTM 1153
COTTER PIN IS STAINLESS STEEL

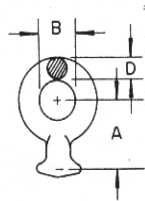

Figure 1

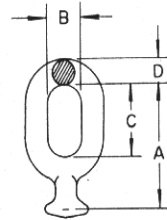

Figure 2

- Made of forged steel.
- Hot dip galvanized.

CATALOG NUMBER	FIGURE NO.	BALL ANSI CLASS	DIM. "A"	DIM. "B"	DIM. "C"	DIM. "D"	ULTIMATE STRENGTH	WT. PER 100
OEB - 20	1	52 - 3 ONLY	2 1/4"	1 3/4"	—	9/16"	20000 LBS.	50 LBS.
OEB - 30	2	52 - 3 52 - 5	3 11/16"	1"	2"	11/16"	30000 LBS.	98 LBS.
OEB - 50	2	52 - 8 52 - 11	4 1/2"	1 1/4"	2 1/2"	3/4"	50000 LBS.	153 LBS.

THE ABOVE HOT LINE LINKS ARE PRIMARILY USED TO CONNECT BALL AND SOCKET INSULATORS TO OTHER HARDWARE. THEY ARE MOST COMMONLY USED ALONG WITH AN ANCHOR SHACKLE FOR TOWER CONNECTIONS.

MATERIAL : HOT DIPPED GALVANIZED STEEL TO ASTM A153

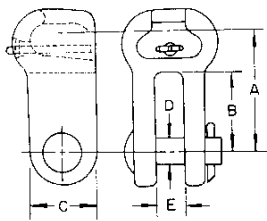

FIGURE 1

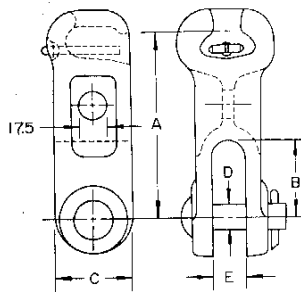

FIGURE 2

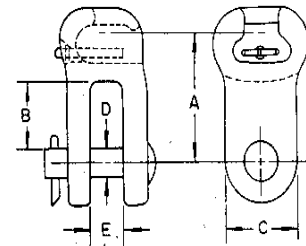

FIGURE 3

CATALOG NUMBER	FIG. NO.	BALL ANSI CLASS	DIM. "A"	DIM. "B"	DIM. "C"	DIA. "D" PIN	DIM. "E"	ULTIMATE STRENGTH	WEIGHT PER 100
USC - 30	1	52 - 3 52 - 5	2 5/8"	1 5/8"	1 3/4"	5/8"	7/8"	30000 LBS.	198 LBS.
USC - 30 - AHM	2	52 - 3 52 - 5	4 1/2"	1 15/16"	1 3/4"	5/8"	7/8"	30000 LBS.	345 LBS.
USC - 30 - 90	3	52 - 3 52 - 5	3 7/8"	2 7/8"	1 3/4"	5/8"	1 1/8"	30000 LBS.	296 LBS.
USC - 50	1	52 - 8 52 - 11	3 9/32"	2 1/16"	2 1/4"	7/8"	1 1/8"	50000 LBS.	455 LBS.
USC - 50 - L	1	52 - 8 52 - 11	4 15/32"	2"	2 1/4"	7/8"	15/16"	50000 LBS.	490 LBS.

THE ABOVE SOCKET CLEVISES ARE USED TO CONNECT BALL AND SOCKET INSULATORS.
OTHER SIZES ARE AVAILABLE UPON REQUEST.

THE MATERIAL IS AS FOLLOWS :
 BODY : FORGED STEEL
 CLEVIS PIN OR BOLT : HIGH GRADE STEEL
 COTTER KEY : STAINLESS STEEL
 FERROUS PARTS ARE HOT DIPPED GALVANIZED TO ASTM A153

SOCKET CLEVIS LINKS & OVAL EYE BALL LINKS

6-11

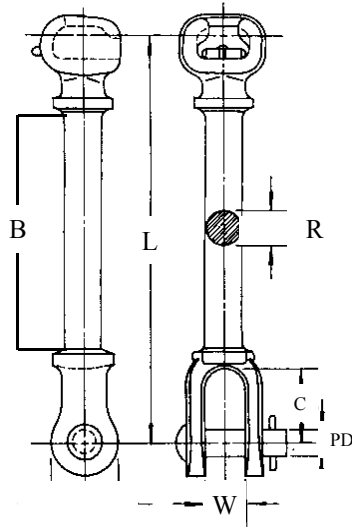

FIG. 1

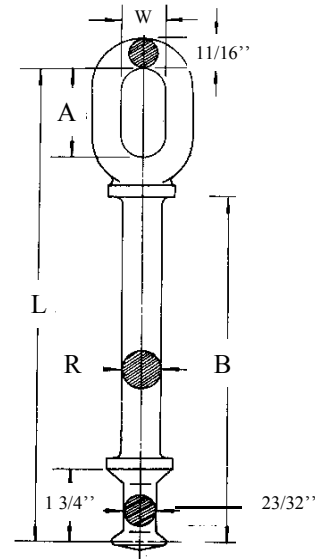
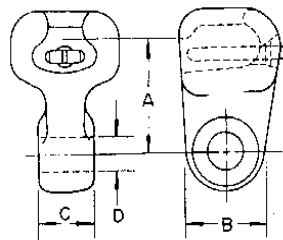

FIG. 2

CATALOG NUMBER	FIG. NO.	ULTIMATE STRENGTH	DIM. L	DIM. A	DIM. B	DIM. C	DIM. R	DIM. W	DIM. PD	APPROX. WEIGHT PER 100
HLSC - 8	1	30000 LBS.	8 3/8"	—	4 5/8"	1 1/2"	7/8"	1"	5/8"	302 LBS.
HLSC - 10	1	30000 LBS.	10"	—	6 1/4"	1 1/2"	7/8"	1"	5/8"	347 LBS.
HLSC - 10 - 35	1	35000 LBS.	11"	—	6 3/32"	1 5/8"	1 1/32"	1"	3/4"	445 LBS.
HLSC - 11 - 50 *	1	50000 LBS.	11"	—	6 13/16"	2"	1 3/16"	1 5/16"	7/8"	698 LBS.
HLSC - 11 - 50A*	1	50000 LBS.	11"	—	6 13/16"	2"	1 3/16"	1 5/16"	1"	705 LBS.
HBOE - 11 - 30	2	30000 LBS.	11 3/4"	2"	9 9/16"	—	7/8"	1"	—	230 LBS.
HBOE - 11 - 50 *	2	50000 LBS.	11 3/4"	2"	9 9/16"	—	1 3/16"	1"	—	300 LBS.

THE ABOVE HOT LINKS ARE PRIMARILY USED TO ATTACH BALL AND SOCKET INSULATORS TO OTHER TYPES OF HARDWARE. THESE PRODUCTS ARE USED ON ANSI #52 - 3 AND #52 - 5 INSULATORS. AN "*" MARK DESIGNATES USE ON ANSI #52 - 8 AND #52 - 11 INSULATORS.

THE MATERIAL IS DUCTILE IRON HOT DIPPED GALVANIZED TO ASTM A153. COTTER PIN IS STAINLESS STEEL.



CATALOG NUMBER	BALL ANSI CLASS	DIM. "A"	DIM. "B"	DIM. "C"	DIM. "D"	ULTIMATE STRENGTH	WEIGHT PER 100
USE - 04	52 - 3	2 1/8"	1 3/4"	1/2"	11/16"	16000 LBS.	120 LBS.
USE - 05	52 - 3	2 1/8"	1 5/8"	5/8"	11/16"	18000 LBS.	122 LBS.
USE - 06	52 - 3 52 - 5	2 1/8"	1 3/4"	3/4"	11/16"	25000 LBS.	128 LBS.
USE - 06 - A	52 - 3 52 - 5	2 3/4"	2"	3/4"	13/16"	30000 LBS.	175 LBS.
USE - 07	52 - 3 52 - 5	2 1/8"	1 5/8"	7/8"	11/16"	30000 LBS.	132 LBS.
USE - 10	52 - 3 52 - 5	2 1/8"	1 5/8"	1"	11/16"	30000 LBS.	138 LBS.
USE - 11	52 - 3 52 - 5	2 1/8"	1 5/8"	1 1/8"	11/16"	30000 LBS.	146 LBS.
USE - 13	52 - 3 52 - 5	2 1/8"	1 5/8"	1 3/8"	11/16"	30000 LBS.	168 LBS.
USE - 13 - A	52 - 3 52 - 5	2 1/8"	1 5/8"	1 5/16"	11/16"	30000 LBS.	155 LBS.
USE - 15 - 50	52 - 8 52 - 11	3 9/32"	2 1/4"	1 5/8"	11/16"	50000 LBS.	295 LBS.
USE - 20	52 - 8 52 - 11	5 5/16"	2 1/4"	1 3/16"	13/16"	50000 LBS.	578 LBS.
USE - 20 - 1	52 - 8 52 - 11	5 5/16"	2 1/4"	1 7/16"	13/16"	50000 LBS.	584 LBS.
USE - 20 - 2	52 - 8 52 - 11	5 5/16"	2 1/4"	1 1/16"	1 1/16"	50000 LBS.	600 LBS.

THE ABOVE SOCKET CLEVISSES ARE USED TO ATTACH CLAMPS TO BALL AND SOCKET INSULATORS.
OTHER SIZES ARE AVAILABLE UPON REQUEST.

THE MATERIAL IS AS FOLLOWS :
 BODY : FORGED STEEL
 CLEVIS PIN OR BOLT : HIGH GRADE STEEL
 COTTER KEY : STAINLESS STEEL
 FERROUS PARTS ARE HOT DIPPED GALVANIZED TO ASTM A153

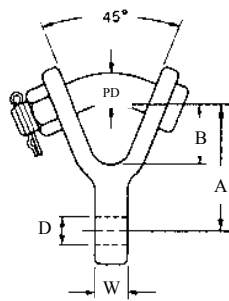

FIGURE 1

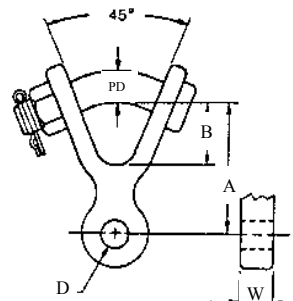
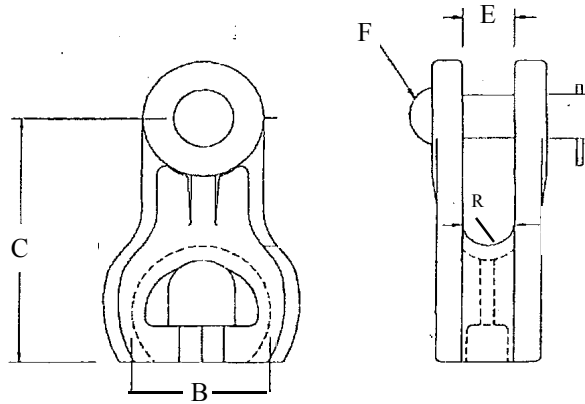

FIGURE 2

CATALOG NUMBER	FIG. NO.	ULTIMATE STRENGTH	DIM. A	DIM. B	DIM. W	DIM. PD	DIA. D	APPROX. WEIGHT PER 100
UYCE – 04	1	19000 LBS.	2 13/16"	1 3/8"	1/2"	3/4"	11/16"	176 LBS.
UYCE – 04 – 90	2	19000 LBS.	2 7/16"	1 5/8"	1/2"	3/4"	11/16"	176 LBS.
UYCE – 05	1	20000 LBS.	2 13/16"	1 3/8"	5/8"	3/4"	11/16"	186 LBS.
UYCE – 05 – 90	2	20000 LBS.	2 7/16"	1 5/8"	5/8"	3/4"	11/16"	186 LBS.
UYCE – 05 – 90 – 30	2	30000 LBS.	2 7/16"	1 5/8"	5/8"	3/4"	11/16"	186 LBS.
UYCE – 06	1	25000 LBS.	2 13/16"	1 3/8"	3/4"	3/4"	11/16"	190 LBS.
UYCE – 06 – 90	2	25000 LBS.	2 7/16"	1 5/8"	3/4"	3/4"	11/16"	190 LBS.
UYCE – 07	1	30000 LBS.	2 13/16"	1 3/8"	7/8"	3/4"	11/16"	190 LBS.
UYCE – 10	1	30000 LBS.	2 13/16"	1 3/8"	1"	3/4"	11/16"	194 LBS.
UYCE – 10 – 90	2	30000 LBS.	2 7/16"	1 5/8"	1"	3/4"	11/16"	194 LBS.
UYCE – 11	1	30000 LBS.	2 13/16"	1 3/8"	1 1/8"	3/4"	11/16"	200 LBS.
UYCE – 12 – 90	2	30000 LBS.	2 7/16"	1 5/8"	1 1/4"	3/4"	11/16"	248 LBS.
UYCE – 13 – 90	2	30000 LBS.	2 7/16"	1 5/8"	1 3/8"	3/4"	11/16"	224 LBS.
UYCE – 16 – 90	2	30000 LBS.	2 7/16"	1 5/8"	1 3/4"	3/4"	11/16"	230 LBS.
UYCE – 16 – 90 – 40	2	40000 LBS.	2 3/8"	1 9/16"	1 3/4"	7/8"	13/16"	250 LBS.
UYCE – 20 – 90	2	30000 LBS.	2 7/16"	1 5/8"	2"	3/4"	11/16"	276 LBS.
UYCE – 21 – 90 – 40	2	40000 LBS.	2 3/8"	1 9/16"	2 1/8"	7/8"	13/16"	300 LBS.
UYCE – 22 – 90	2	30000 LBS.	2 7/16"	1 5/8"	2 1/4"	3/4"	11/16"	276 LBS.
UYCE – 24 – 90	2	30000 LBS.	2 7/16"	1 5/8"	2 1/2"	3/4"	11/16"	300 LBS.
UYCE – 26 – 90 – 40	2	40000 LBS.	2 3/8"	1 9/16"	2 3/4"	7/8"	13/16"	346 LBS.

THE ABOVE Y – CLEVIS EYES ARE PRIMARILY USED TO CONNECT YOKE PLATES OR OTHER TOWER HARDWARE TO CONDUCTOR CLAMPS.

THE MATERIAL IS : BODY AND HARDWARE – DUCTILE IRON HOT DIPPED GALVANIZED TO ASTM A153
COTTER PIN – STAINLESS STEEL



CATALOG NUMBER	THIMBLE STRENGTH LBS.	EYE STRENGTH LBS.	DIMENSION "B"	DIMENSION "C"	DIMENSION "E"	DIAMETER "F"	GROOVE "R"
TC20	20,000	12,500	2 1/4"	3 9/16"	7/8"	5/8"	.88"
TC35	35,000	25,000	2 1/4"	4 3/8"	7/8"	3/4"	.88"
TC40	40,000	30,000	2 1/2"	4 7/8"	1 1/16"	3/4"	1.00"
TC60	60,000	40,000	2 1/2"	5 7/8"	1 1/16"	1"	1.00"
TC80	80,000	50,000	2 1/2"	6"	1 1/16"	1 1/4"	1.00"
TC80HD	80,000	50,000	3"	6 1/8"	1 5/16"	1 1/8"	1.31"
TC80HD-P	80,000	66,000	3"	6 1/8"	1 9/16"	1 1/8"	1.31"

THE MATERIAL ON THE ABOVE THIMBLE CLEVISES IS AS FOLLOWS :

BODY : DUCTILE IRON

COTTER PIN : STEEL

COTTER KEY : STAINLESS STEEL

HOT DIPPED GALVANIZED TO ASTM A153 OR BS 729

TOWER EXTENSION STRAPS

6-15

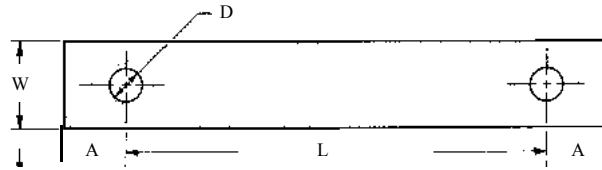

CATALOG NUMBER	ULTIMATE STRENGTH	DIM. A	DIM. L	DIM. W	STRAP THICKNESS	HOLES DIAMETER D	APPROX. WEIGHT PER 100
TES - 10	10,000 LBS.	3/4"	4"	1 1/2"	1/4"	11/16"	55 LBS.
TES - 20	20,000 LBS.	7/8"	4"	1 1/2"	1/2"	11/16"	110 LBS.
TES - 30	30,000 LBS.	1 1/8"	4"	2"	3/4"	15/16"	260 LBS.
TES - 40	40,000 LBS.	1 1/2"	4"	2 1/2"	3/4"	15/16"	365 LBS.
TES - 60	60,000 LBS.	2"	4"	2 1/2"	1"	1 1/8"	560 LBS.
TES - 80	80,000 LBS.	2"	4"	3"	1"	1 1/4"	670 LBS.

THE ABOVE EXTENSION STRAPS ARE PRIMARILY USED TO OBTAIN PROPER TOWER CLEARANCE WITHIN A TRANSMISSION ASSEMBLY. THEY MAY BE ATTACHED TO A VARIETY OF ASSOCIATED HARDWARE. THESE STRAPS CAN BE FURNISHED IN MANY OTHER SIZES. PLEASE CONTACT UPI WITH YOUR SPECIFIC REQUIREMENTS.

THE MATERIAL USED IS STEEL HOT DIPPED GALVANIZED TO ASTM A153.

TURNBUCKLES HOT DIPPED GALVANIZED

6-16

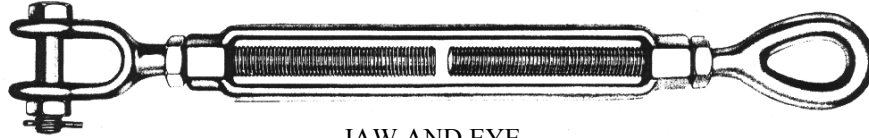

JAW AND EYE

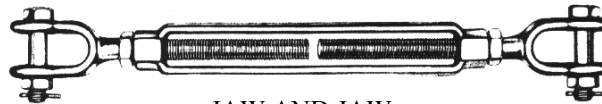

JAW AND JAW



EYE AND EYE

CATALOG NUMBER			SIZE AND TAKE UP	ULTIMATE STRENGTH	APPROXIMATE WEIGHT PER EACH		
JAW/EYE	JAW/JAW	EYE/EYE			JAW/EYE	JAW/JAW	EYE/EYE
JE586	JJ586	EE586	5/8" X 6"	16000 LBS.	2.8 LBS.	3.0 LBS.	2.7 LBS.
JE589	JJ589	EE589	5/8" X 9"	16000 LBS.	3.5 LBS.	3.7 LBS.	3.2 LBS.
JE5812	JJ5812	EE5812	5/8" X 12"	16000 LBS.	4.0 LBS.	4.2 LBS.	3.6 LBS.
JE346	JJ346	EE346	3/4" X 6"	25000 LBS.	4.5 LBS.	4.9 LBS.	4.0 LBS.
JE349	JJ349	EE349	3/4" X 9"	25000 LBS.	5.2 LBS.	5.6 LBS.	4.7 LBS.
JE3412	JJ3412	EE3412	3/4" X 12"	25000 LBS.	6.4 LBS.	6.7 LBS.	6.0 LBS.
JE3418	JJ3418	EE3418	3/4" X 18"	25000 LBS.	7.6 LBS.	8.0 LBS.	7.2 LBS.
JE7812	JJ7812	EE7812	7/8" X 12"	35000 LBS.	8.6 LBS.	9.0 LBS.	8.2 LBS.
JE7818	JJ7818	EE7818	7/8" X 18"	35000 LBS.	11.9 LBS.	12.7 LBS.	10.7 LBS.
JE112	JJ112	EE112	1" X 12"	45000 LBS.	12.7 LBS.	13.8 LBS.	12.0 LBS.
JE114	JJ114	EE114	1" X 14"	45000 LBS.	14.2 LBS.	15.3 LBS.	13.4 LBS.
JE118	JJ118	EE118	1" X 18"	45000 LBS.	15.5 LBS.	16.7 LBS.	14.4 LBS.
JE124	JJ124	EE124	1" X 24"	45000 LBS.	17.7 LBS.	18.8 LBS.	16.4 LBS.
JE11412	JJ11412	EE11412	1 1/4" X 12"	67500 LBS.	21.2 LBS.	23.4 LBS.	18.9 LBS.
JE11418	JJ11418	EE11418	1 1/4" X 18"	67500 LBS.	25.3 LBS.	27.6 LBS.	23.3 LBS.
JE11424	JJ11424	EE11424	1 1/4" X 24"	67500 LBS.	30.7 LBS.	32.0 LBS.	27.3 LBS.
JE11212	JJ11212	EE11212	1 1/2" X 12"	105500 LBS.	35.0 LBS.	40.0 LBS.	30.0 LBS.
JE11218	JJ11218	EE11218	1 1/2" X 18"	105500 LBS.	40.0 LBS.	44.0 LBS.	36.0 LBS.

YOKE PLATES DELTA STYLE

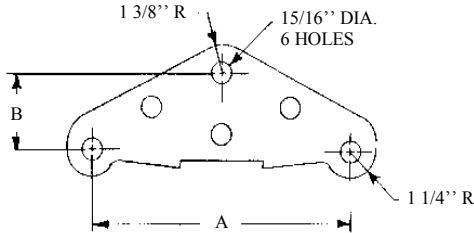

FIG. 1

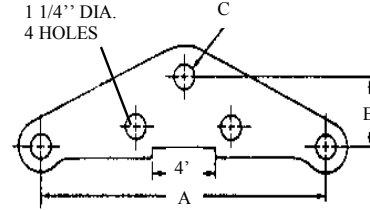

FIG. 2

CATALOG NUMBER	FIGURE NO.	PLATE MATERIAL	ULTIMATE STRENGTH	DIM. A	DIM. B	DIM. C	PLATE THICKNESS
DYP30 – 18	1	DUCTILE	30000 LBS.	18"	3 5/8"	—	3/4"
DYP40 – 13S	1	STEEL	40000 LBS.	13"	3 5/8"	—	5/8"
DYP50 – 18	1	DUCTILE	50000 LBS.	18"	5"	—	3/4"
DYP60 – 13S	1	STEEL	60000 LBS.	13"	3 5/8"	—	3/4"
DYP30 – 13P	2	DUCTILE	30000 LBS.	13"	6"	15/16"	5/8"
DYP50 – 18P	2	DUCTILE	50000 LBS.	18"	5"	1 1/4"	3/4"
DYP60 – 18P	2	DUCTILE	60000 LBS.	18"	5"	1 1/4"	3/4"

THE ABOVE DELTA STYLE YOKE PLATES ALONG WITH A SINGLE STRING OF INSULATORS CAN BE USED TO BUNDLE TWO CONDUCTORS IN SUSPENSION. THEY MAY ALSO BE USED IN DEADENDING IN CONJUNCTION WITH TWO STRINGS OF INSULATORS AND ONE DEADEND CLAMP. THIS PRODUCT CAN BE SUPPLIED IN A VARIETY OF CONFIGURATIONS. FROM HOLE SPACING TO PLATE THICKNESS, UPI CAN HANDLE YOUR CUSTOM REQUESTS.

THE MATERIAL IS DUCTILE IRON OR STEEL (SUFFIX "S") HOT DIPPED GALVANIZED A153.

YOKE PLATES RECTANGULAR STYLE

6-18

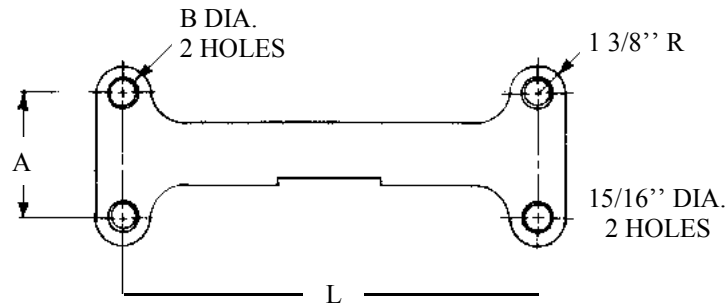

CATALOG NUMBER	ULTIMATE STRENGTH AT EACH HOLE	PLATE MATERIAL	DIM. L	DIM. A	DIM. B	PLATE THICKNESS
RYP30 – 18 – 5/8 S	30000 LBS.	STEEL	18"	5"	15/16"	5/8"
RYP40 – 18 – 3/4 S	40000 LBS.	STEEL	18"	5"	15/16"	3/4"
RYP30 – 13C – 3/4	30000 LBS.	DUCTILE	13"	4 1/2"	1"	3/4"
RYP30 – 18C – 3/4	30000 LBS.	DUCTILE	18"	6"	1 1/4"	3/4"

THE ABOVE RECTANGULAR STYLE YOKE PLATES ALONG WITH A DOUBLE STRING OF INSULATORS CAN BE USED TO DEADEND A TWO CONDUCTOR BUNDLE. THIS PRODUCT CAN BE SUPPLIED IN A VARIETY OF CONFIGURATIONS. THE SERIES WITH THE SUFFIX "C" REPRESENT PLATES FURNISHED WITH A CENTER HOLE. FROM HOLE SPACING TO PLATE THICKNESS, UPI CAN HANDLE YOUR CUSTOM REQUESTS.

THE MATERIAL IS DUCTILE IRON OR STEEL (ADD THE SUFFIX "S") HOT DIPPED GALVANIZED TO ASTM A153.